

ARGANO FT3-1000 / GEAR BOX FT3-1000



- | | |
|---|--|
| - CARICO STATICO MAX
MAX STATIC LOAD | 4500 KG |
| - POTENZE MOTORI 50 Hz 4 POLI VVVF
RANGE POWER | 7.50 / 21.00 KW |
| - POTENZE MOTORI 50 Hz 4/16 POLI
RANGE POWER | 7.50 / 21.00 KW |
| - POTENZE MOTORI 60 Hz 4 POLI VVVF
RANGE POWER | 7.50 / 21.00 KW |
| - POTENZE MOTORI 60 Hz 4/16 POLI
RANGE POWER | 7.50 / 21.00 KW |
| - RAPPORTI RIDUZIONE
RATIO | 1/58; 1/52; 1/45; 1/37; 2/47; 2/49; 2/55; 3/37; 3/41 |
| - PESO MACCHINA
GEAR WEIGHT | 429 KG |
| - CAPACITA' OLIO
OIL CAPABILITY | 6.5 L |

ARGANO DX / RH GEAR BOX



ARGANO SX / LH GEAR BOX

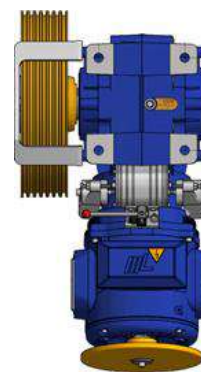

ARGANO FT3-1000 / GEAR BOX FT3-1000

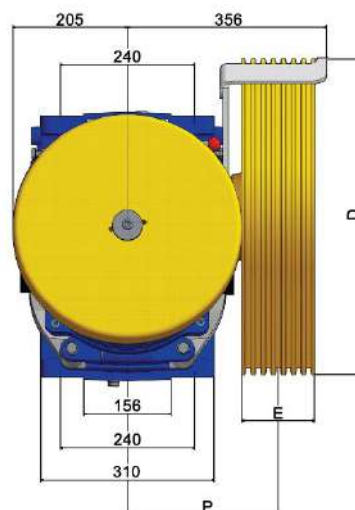
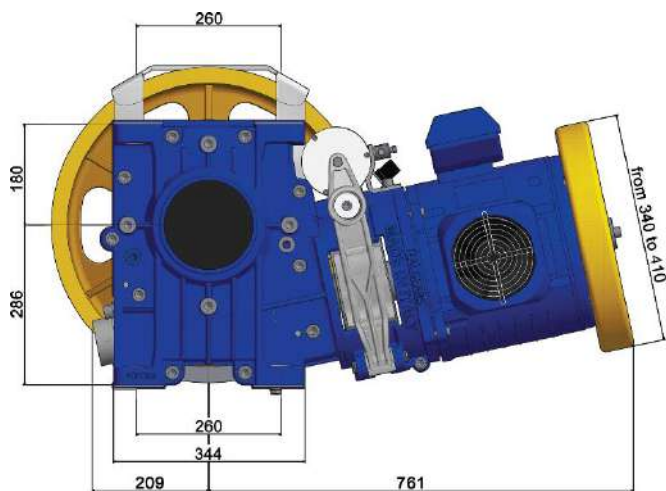

PULEGGIA DI TRAZIONE
TRACTION SHEAVE

DISTANZA
DISTANCE

SPESORE VOLANO
FLYWELL DEPTH

CARICO STATICO
STATIC LOAD

DIREZIONE CARICO STATICO
STATIC LOAD DIRECTION

D (mm)

P (mm)

S (mm)

Kg / Kgs

(%)

450

258

480

258

520

273

15 ÷ 50

4500

100%



100%

550

273

600

273

100%

ELETTROMAGNETE FRENO
BRAKE ELECTROMAGNET

V

A

W

24

4,8

115

48

1,85

90

60

1,43

87

80

1,26

101

110

0,92

101

200

0,52

102

ARGANO FT3_1000 - TABELLE PORTATE 50 Hz / GEAR BOX FT3_1000 - 50 Hz DUTY TABLE

VVVF 1500Rpm 4 poli 50 Hz SOSPENSIONE1:1

AC2 1500/375Rpm 4/16 poli 50 Hz ROPING 1:1

Velocità Sincrona Speed synchronous m/s	Diametro puleggia trazione Traction sheave diam. mm	Rapporto riduzione Ratio	POTENZE MOTORE SINCRONE KW / OUTPUT MOTOR SYNCHRONOUS KW									
			7,50	9,50	11,00	13,50	15,00	16,00	17,50	19,00	21,00	
			POTENZE MOTORE SINCRONE HP / OUTPUT MOTOR SYNCHRONOUS HP									
			10,00	12,50	15,00	18,00	20,00	22,00	24,00	26,00	28,00	
PORTATE KG / LOADS KG												
0,61	450	1:58	1500	1600								
0,65	480	1:58	1250	1500								
0,68	450	1:52	1200	1500								
0,70	520	1:58	1150	1380								
0,72	480	1:52	1100	1390								
0,76	560	1:58	1050	1280								
0,79	450	1:45	1050	1300	1550							
0,79	520	1:52	1000	1280	1380							
0,81	600	1:58	960	1200								
0,84	480	1:45	960	1200	1470	1520						
0,85	560	1:52	950	1100	1300							
0,91	520	1:45	900	1150	1370	1400						
0,91	600	1:52	900	1100	1200							
0,95	450	1:37	870	1100	1300	1400						
0,98	560	1:45	850	1050	1270	1390						
1,02	480	1:37	830	1030	1240	1350						
1,05	600	1:45	820	1030	1200	1300						
1,10	520	1:37	830	1050	1270	1500						
1,19	560	1:37	780	980	1180	1390						
1,27	600	1:37	700	890	1100	1300						
1,50	450	2:47	640	800	970	1150	1300	1400				
1,60	480	2:47	600	760	900	1100	1200	1330				
1,74	520	2:47	560	700	840	1000	1100	1230				
1,87	560	2:47	520	650	800	950	1050	1150				
2,00	600	2:47	485	600	730	870	970	1050	1100			
3,31	520	3:37	300	370	450	540	600	670	730	800	850	

SOLO PER VVVF

ONLY VVVF

Posizione argano= Alto
 Contrappeso = 50%
 Rendimento = 0,80
 non comprendono il peso delle funi
 Per conoscere la portata netta sottrarre
 2 volte il peso delle funi

Position of gear box = Up
 Counterweight = 50%
 Plant efficiency = 0,80
 Loads don't include weight ropes
 In order to know the net capability subtract twice weight
 ropes

ARGANO FT3_1000 - TABELLE PORTATE 60Hz / GEAR BOX FT3_1000 - 60 Hz DUTY TABLE

VVVF 1800 Rpm 4 poli 60 Hz SOSPENSIONE1:1

AC2 1800/450 Rpm 4/16 poli 60 Hz ROPING 1:1

Velocità Sincrona Speed synchronous m/s	Diametro puleggia trazione Traction sheave diam. mm	Rapporto riduzione Ratio	POTENZE MOTORE SINCRONE KW / OUTPUT MOTOR SYNCHRONOUS KW								
			7,50	9,50	11,00	13,50	15,00	16,00	18,00	19,00	21,00
			POTENZE MOTORE SINCRONE HP / OUTPUT MOTOR SYNCHRONOUS HP								
			10,00	12,50	15,00	18,00	20,00	22,00	24,00	26,00	28,00
PORTATE KG / LOADS KG											
0,73	450	1:58	1100	1400	1600						
0,78	480	1:58	1050	1300	1500						
0,82	450	1:52	1000	1250	1500	1600					
0,84	520	1:58	950	1200	1400						
0,87	480	1:52	959	1200	1400	1500					
0,91	560	1:58	900	1100	1280						
0,94	450	1:45	900	1100	1300	1600					
0,94	520	1:52	900	1100	1300	1400					
0,97	600	1:58	800	1050	1200						
1,00	480	1:45	830	1000	1250	1500	1600				
1,01	560	1:52	800	1000	1200	1300					
1,09	520	1:45	750	1000	1200	1430	1500				
1,09	600	1:52	750	1000	1200	1200					
1,17	560	1:45	700	900	1100	1400					
1,26	600	1:45	650	850	1000	1250	1300				
1,54	450	2:55	600	730	900	1150	1250	1400			
1,64	480	2:55	540	700	850	1050	1200	1300			
1,78	520	2:55	500	630	800	1000	1100	1200			
1,92	560	2:55	450	600	730	900	1000	1100			
2,00	520	2:49	450	560	700	880	970	1100	1200		
3,31	480	3:41	380	400	450	550	600	670	730	800	860

SOLO PER VVVF

ONLY VVVF

Posizione argano= Alto

Contrappeso = 50%

Rendimento = 0,80

non comprendono il peso delle funi

Per conoscere la portata netta sottrarre

2 volte il peso delle funi

Position of gear box = Up

Counterweight = 50%

Plant efficiency = 0,80

Loads don't include weight ropes

In order to know the net capability subtract twice weight

ropes

ARGANO FT3-1000 – DATI ELETTRICI MOTORI 50Hz / GEAR BOX FT3-1000 – 50 Hz ELECTRICAL MOTOR DATA

AC2 1500/375 Rpm 4 /16Poli 50 Hz

PARAMETRI MOTORE <i>MOTOR PARAMETERS</i>		POTENZA NOMINALE SINCRONA KW / SYNCHRONOUS NOMINAL POWER KW			
		7,50	9,50	11,00	13,50
		POTENZA NOMINALE SINCRONA HP / SYNCHRONOUS NOMINAL POWER HP			
		10,00	12,50	15,00	18,00
Tensione nominale / Nominal voltage	V	400	400	400	400
Frequenza / Frequency	HZ	50	50	50	50
Giri Sincroni / Synchronous speed	RPM	1500/375	1500/375	1500/375	1500/375
Corrente nominale / Nominal current +/- 5%	A	9,40	16,00	14,00	14,00
Ciclo di lavoro / Duty cycle	%	(S4-40%)	(S4-40%)	(S4-40%)	(S4-40%)
Classe protezione / Protection class	IP	21	21	21	21
Classe isolamento / Insulation class		F	F	F	F

VVVF 1500 Rpm 4 Poli 50 Hz

PARAMETRI MOTORE <i>MOTOR PARAMETERS</i>		POTENZA NOMINALE SINCRONA KW / SYNCHRONOUS NOMINAL POWER KW							
		7,50	9,50	11,00	13,50	15,00	16,00	17,50	19,00
		POTENZA NOMINALE SINCRONA HP / SYNCHRONOUS NOMINAL POWER HP							
		10,00	12,50	15,00	18,00	20,00	22,00	24,00	26,00
Tensione nominale / Nominal voltage	V	400	400	400	400	400	400	400	400
Frequenza / Frequency	HZ	50	50	50	50	50	50	50	50
Giri Sincroni / Synchronous speed	RPM	1500	1500	1500	1500	1500	1500	1500	1500
Corrente nominale / Nominal current +/- 5%	A	17,00	22,00	23,50	30,00	31,00	35,00	36,00	40,00
Ciclo di lavoro / Duty cycle	%	(S - 60%)	(S - 60%)	(S - 60%)	(S - 60%)	(S - 60%)	(S - 60%)	(S - 60%)	(S - 60%)
Classe protezione / Protection class	IP	21	21	21	21	21	21	21	21
Classe isolamento / Insulation class		F	F	F	F	F	F	F	F

Motori configurati a singolo voltaggio
Per tensione motore 230V(220v) le correnti
nominali devono essere moltiplicate per 1,73
ventilatore incluso 1/220...240V 50/60Hz
ventilatore 115 volt disponibile su richiesta

Motors stamped for sigle voltage
For 230V(220V) motor voltage,listed
nominal current must be multiplied for 1,73
include fan 1/220...240V 50/60Hz
fan 115 volt supplied on demand

ARGANO FT3-1000 – DATI ELETTRICI MOTORI 60Hz / GEAR BOX FT3-1000 – 60 Hz ELECTRICAL MOTOR DATA

AC2 1800/450 Rpm 4 /16Poli 60 Hz

PARAMETRI MOTORE MOTOR PARAMETERS		POTENZA NOMINALE SINCRONA KW / SYNCHRONOUS NOMINAL POWER KW				
		7,50	9,50	11,00	13,50	15,00
		POTENZA NOMINALE SINCRONA HP / SYNCHRONOUS NOMINAL POWER HP				
		10,00	12,50	15,00	18,00	20,00
Tensione nominale / Nominal voltage	V	380	380	380	380	380
Frequenza / Frequency	HZ	60	60	60	60	60
Giri Sincroni / Synchronous speed	RPM	1800/450	1800/450	1800/450	1800/450	1800/450
Corrente nominale / Nominal current +/- 5%	A	10,00	18,00	15,00	16,00	18,00
Ciclo di lavoro / Duty cycle	%	(S - 40%)	(S - 40%)	(S - 40%)	(S - 40%)	(S - 40%)
Classe protezione / Protection class	IP	21	21	21	21	21
Classe isolamento / Insulation class		F	F	F	F	F

VVVF 1800 Rpm 4 Poli 60 Hz

PARAMETRI MOTORE MOTOR PARAMETERS		POTENZA NOMINALE SINCRONA KW / SYNCHRONOUS NOMINAL POWER KW						
		7,50	9,50	11,00	13,50	15,00	16,00	18,00
		POTENZA NOMINALE SINCRONA HP / SYNCHRONOUS NOMINAL POWER HP						
		10,00	12,50	15,00	18,00	20,00	22,00	25,00
Tensione nominale / Nominal voltage	V	380	380	380	380	380	380	380
Frequenza / Frequency	HZ	60	60	60	60	60	60	60
Giri Sincroni / Synchronous speed	RPM	450	450	450	450	450	450	450
Corrente nominale / Nominal current +/-5%	A	14,00	22,50	27,00	29,50	33,00	34,00	42,00
Ciclo di lavoro / Duty cycle	%	(S- 60%)	(S- 60%)	(S- 60%)	(S- 60%)	(S- 60%)	(S- 60%)	(S- 60%)
Classe protezione / Protection class	IP	21	21	21	21	21	21	21
Classe isolamento / Insulation class		F	F	F	F	F	F	F

Motori configurati a singolo voltaggio
Per tensione motore 230V(220v) le correnti
nominali devono essere moltiplicate per 1,73
ventilatore incluso 1/220...240V 50/60Hz
ventilatore 115 volt disponibile su richiesta

Motors stamped for sigle voltage
For 230V(220V) motor voltage,listed
nominal current must be multiplied for 1,73
include fan 1/220...240V 50/60Hz
fan 115 volt supplied on demand

ARGANO FT3-1000 - PULEGGE DI TRAZIONE / GEAR BOX FT3-1000 - TRACTION SHEAVES

SISTEMA AVVOLGIMENTO ROPE SYSTEM	PULEGGIA DI TRAZIONE TRACTION SHEAVE		NUMERO GOLE X D ROPE NUMBER X D	INTERASSE GOLE ROPE DISTANCE I (mm)
	D (mm)	E (mm)		
CSW	450	130	8XD8	12
	450	130	7XD9	16
	450	130	6XD10	16
	450	130	6XD11	18
	450	130	5XD12	18
	450	130	5XD13	19
	480	130	8XD8	12
	480	130	7XD9	16
	480	130	6XD10	16
	480	130	6XD11	18
	480	130	5XD12	18
	480	130	5XD13	19
	520	130	8XD8	12
	520	130	7XD9	16
	520	130	6XD10	16
	520	130	6XD11	18
	520	130	5XD12	18
	520	130	5XD13	19
	550	130	8XD8	12
	550	130	7XD9	16
	550	130	6XD10	16
	550	130	6XD11	18
	550	130	5XD12	18
	550	130	5XD13	19
	600	130	8XD8	12
	600	130	7XD9	16
	600	130	6XD10	16
	600	130	6XD11	18
	600	130	5XD12	18
	600	130	5XD13	19

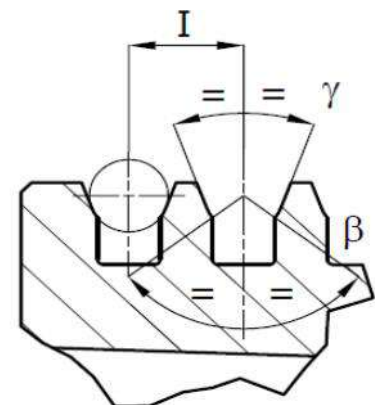

Gola a U con sottointaglio
U grooves with undercut

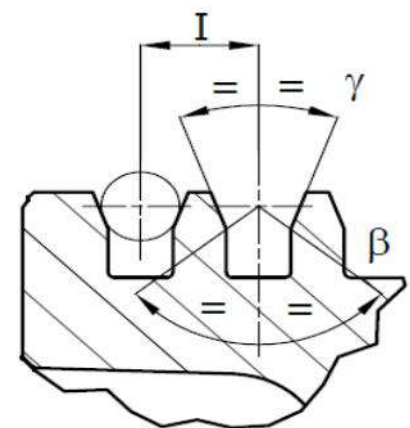

Gola a V con sottointaglio
V grooves with undercut

Y = ANGOLO GOLA / GROOVE ANGLE

β = ANGOLO SOTTOINTAGLIO / UNDERCUT ANGLE

ARGANO FT3-1000 - PULEGGE DI DEVIAZIONE / GEAR BOX FT3-1000 - DIVERTOR PULLEY

PULEGIA DI DEVIAZIONE DIVERTING PULLEY		N. GOLE X D N. ROPE X D	INTERASSE GOLE ROPE DISTANCE	LUNGHEZZA ALBERO SHAFT LENGHT	DIAMETRO ALBERO SHAFT DIAMETER
P (mm)	A (mm)		C (mm)	Z (mm)	R (mm)
320	130	10XD8	15	184	60
360	130	10XD9	12	184	60
400	130	7XD10	17	184	60
		6XD11	17	184	60
		6XD12	20	164	60
		6XD13	20	164	60
450	130	8XD9	17	164	60
		8XD11	17	164	60
		6XD12	20	164	60
		6XD13	20	164	60
500	130	7XD9	17	164	60
		7XD11	17	164	60
		6XD12	20	164	60
550	130	6XD13	20	164	60

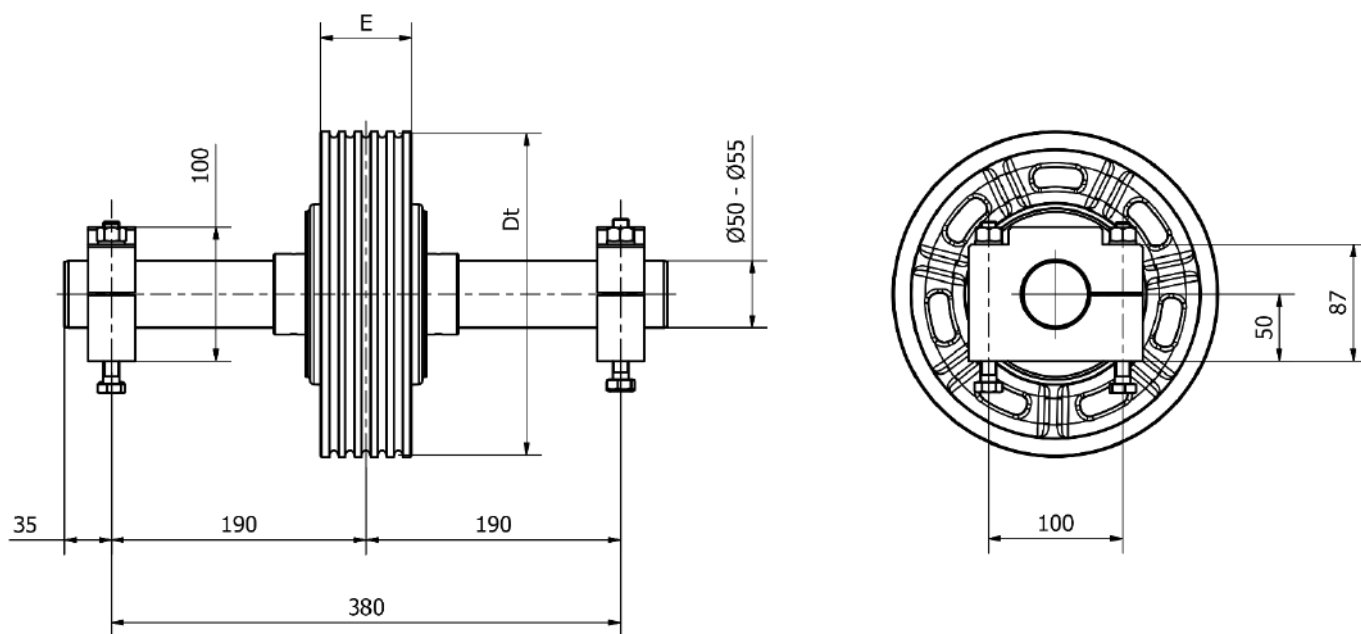

ARGANO FT3-1000 MACCHINA IN ALTO SENZA PULEGGIA DI DEVIAZIONE AVVOLGIMENTO CSW
 GEARBOX FT3-1000 TOP MACHINE WITHOUT DIVERTOR PULLEY CWS ROPING

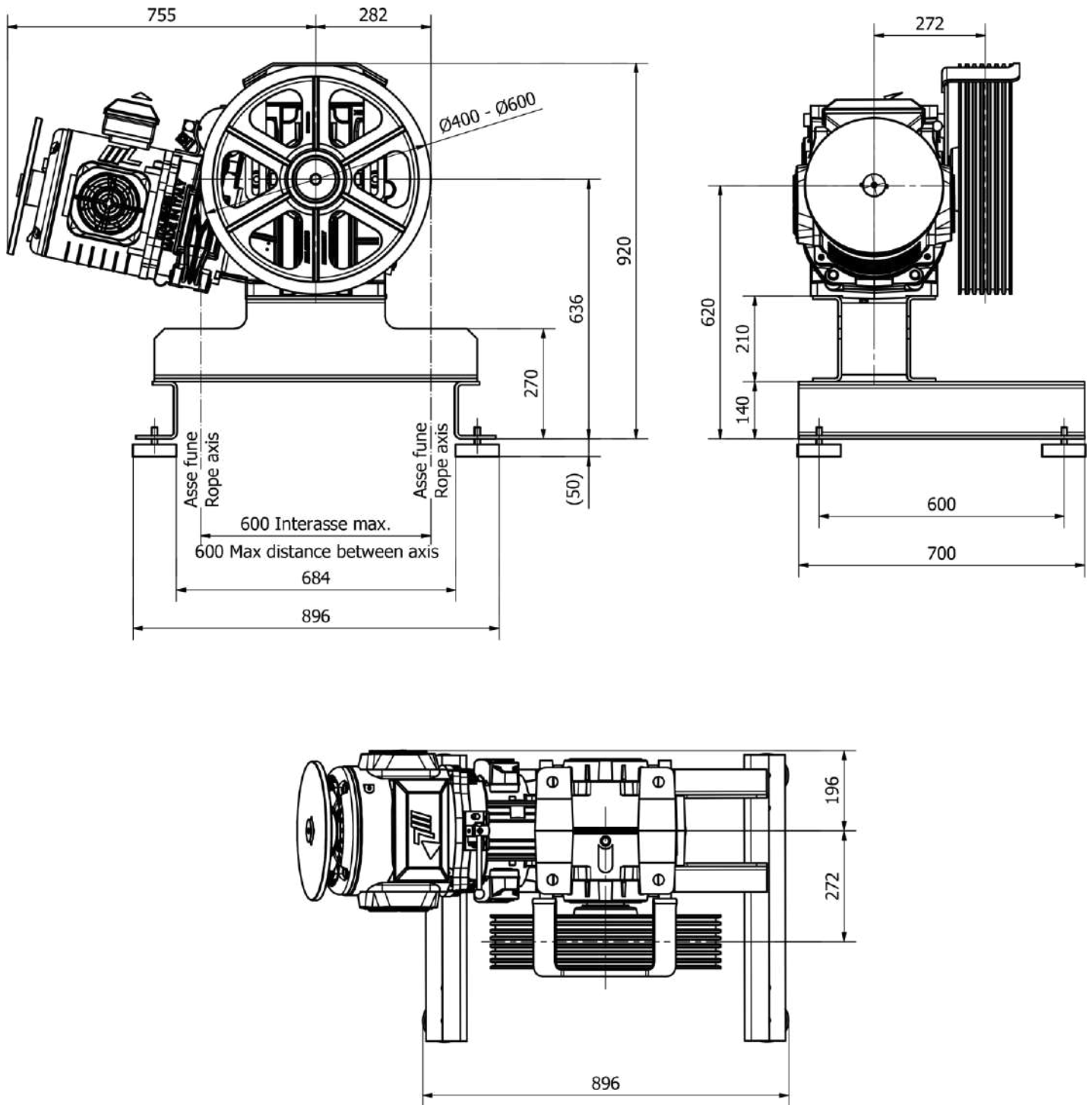

ARGANO FT3-1000 MACCHINA IN ALTO PULEGGIA DI DEVIAZIONE AVVOLGIMENTO CSW
GEARBOX FT3-1000 TOP MACHINE WITH DIVERTOR PULLEY CWS ROPING

